

IG0080 - OHD or Vert. Lift Door Header w/ Secondary Member Above

IG0081 - OHD or Vert. Lift Header w/ Add'l Support Channel

IG0082 - At Roll-Up Door Header

IG0085 - Header w/ Eave Strut Above

IG0091 - Walkdoor or Window Header

IG0095 - Sill Detail

### **Jamb Details**

IG0151 - w/KW

IG0251 - w/KR2

IG0351 - w/KRP

### **Ceiling Opening Details**

IG0120 - Opening w/ KW Liner

IG0220 - Opening w/KR2 Liner

IG0320 - Opening w/KRP Liner

---

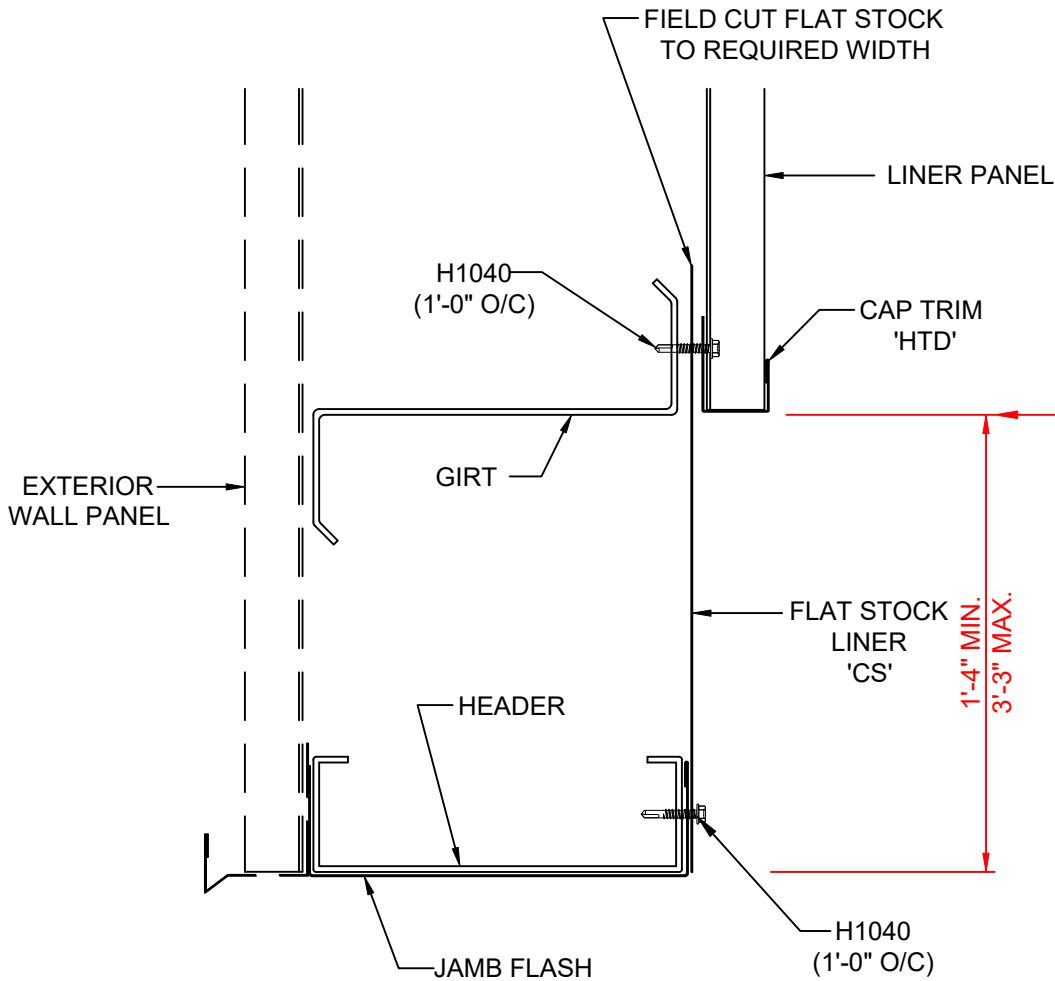

NOTE: JAMB TRIM MUST BE LONG ENOUGH TO REACH THE HEADER TRIM.

FOR EXAMPLE, AT A 10'-0" TALL OPENING, JTR122 WILL NOT BE LONG ENOUGH!

**IG0080K**

LINER AT OHD OR VERT. LIFT DOOR HEADER  
w/ SECONDARY MEMBER 1'-4" - 3'-3" ABOVE HEADER

ADD HEADER WHEN A BUILDING SECONDARY MEMBER IS NOT 1'-4" TO 3'-3" ABOVE DOOR HEADER

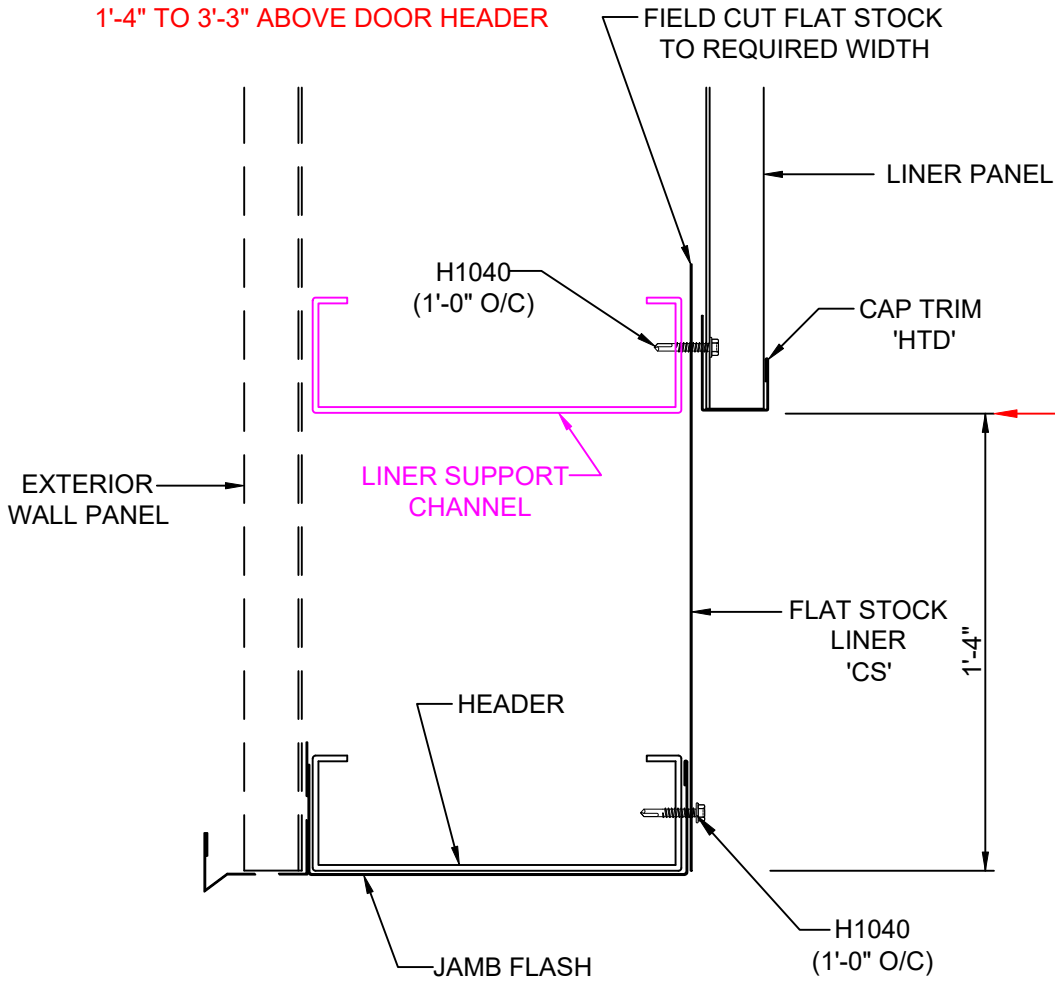

NOTE: JAMB TRIM MUST BE LONG ENOUGH TO REACH THE HEADER TRIM.

FOR EXAMPLE, AT A 10'-0" TALL OPENING, JTR122 WILL NOT BE LONG ENOUGH!

IG0081K

LINER AT OHD OR VERT. LIFT DOOR HEADER w/ LINER SUPPORT CHANNEL ABOVE HEADER

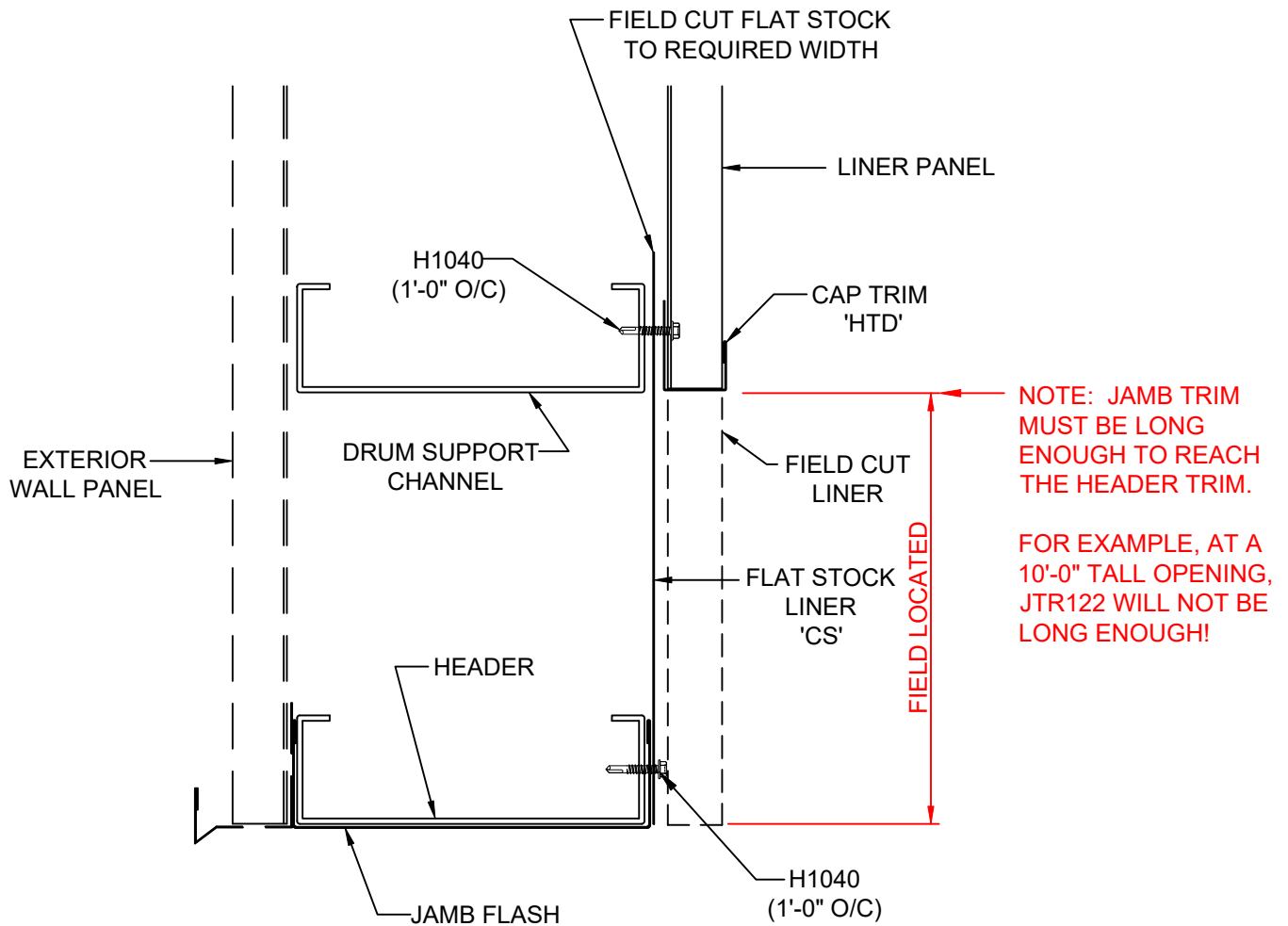

IG0082K

LINER AT ROLL UP DOOR HEADER

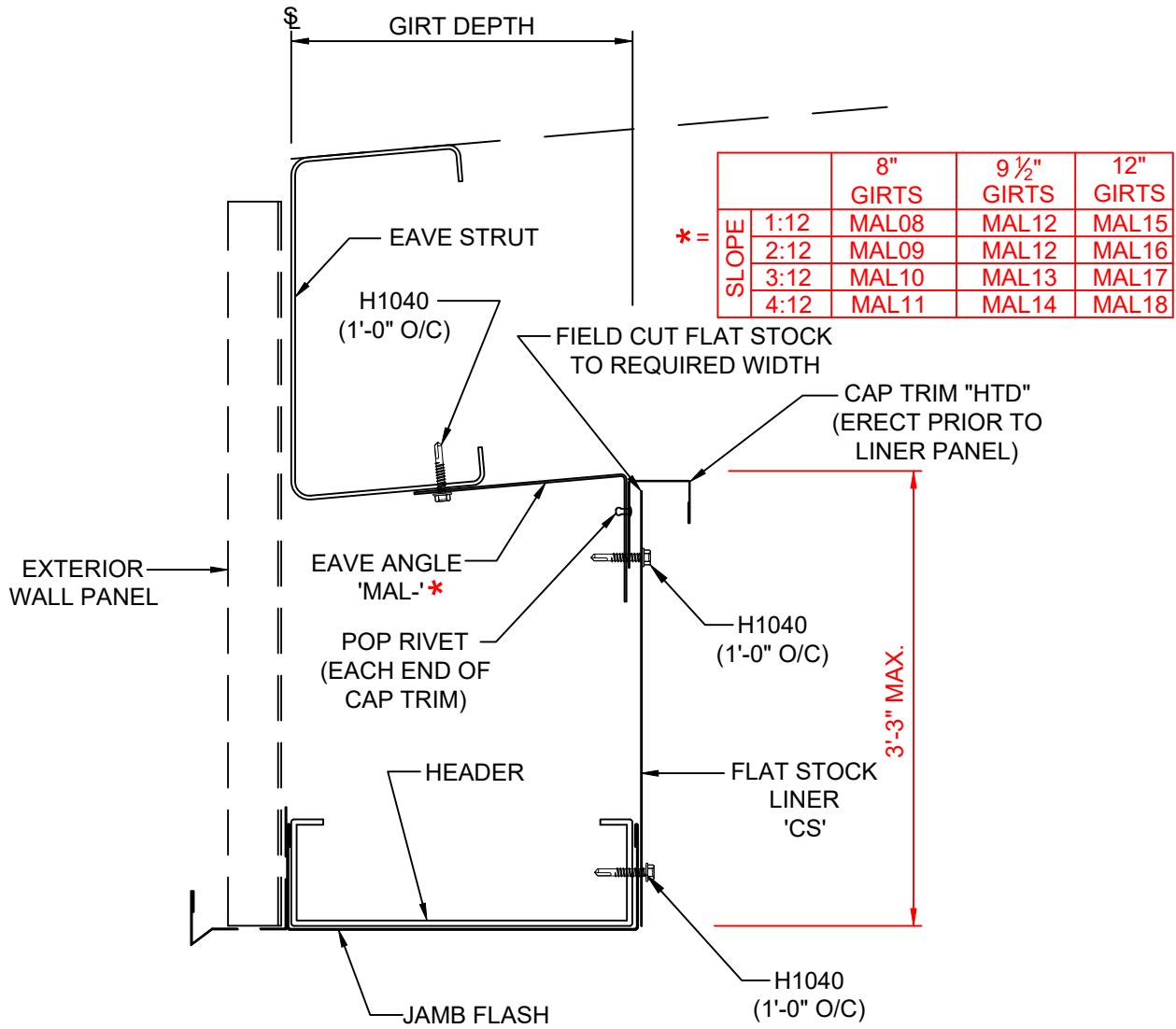

**IG0085K**

**LINER AT HEADER WITH EAVE STRUT  
< 3'-3" ABOVE HEADER**

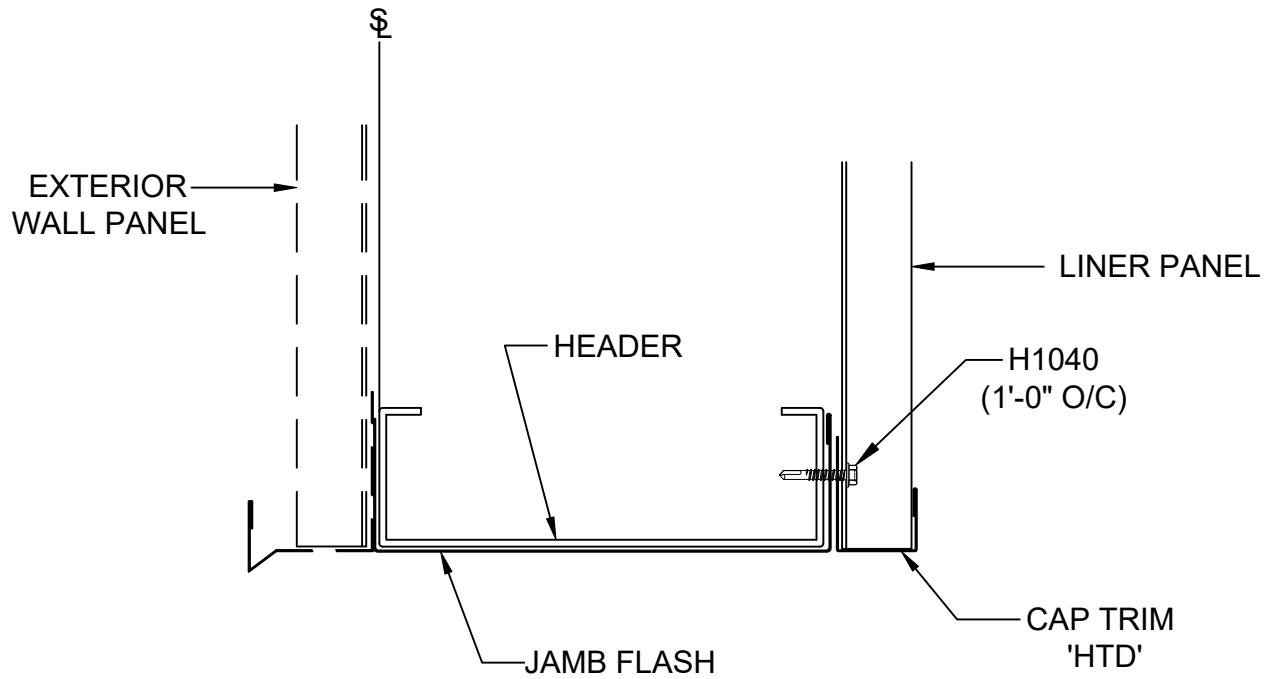

IG0091K

LINER AT WALKDOOR OR WINDOW HEADER

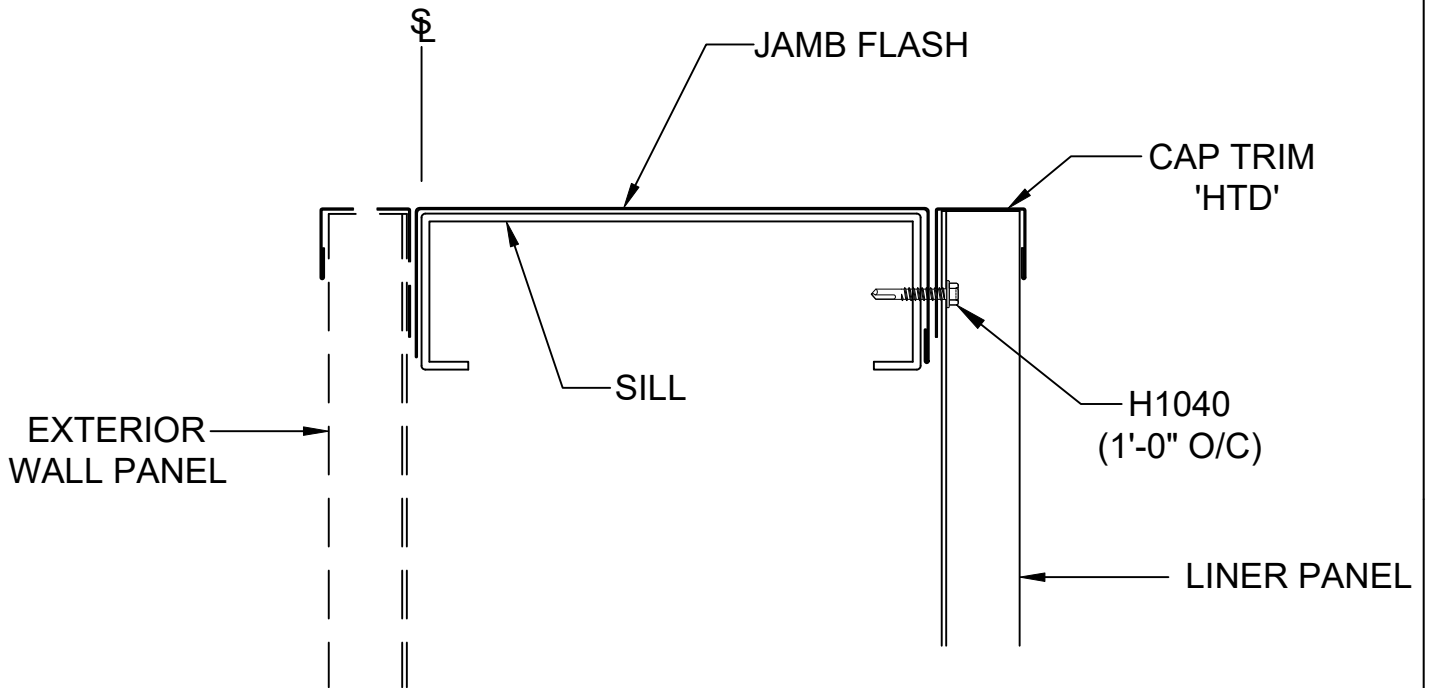

**IG0095K**

**LINER AT SILL DETAIL**

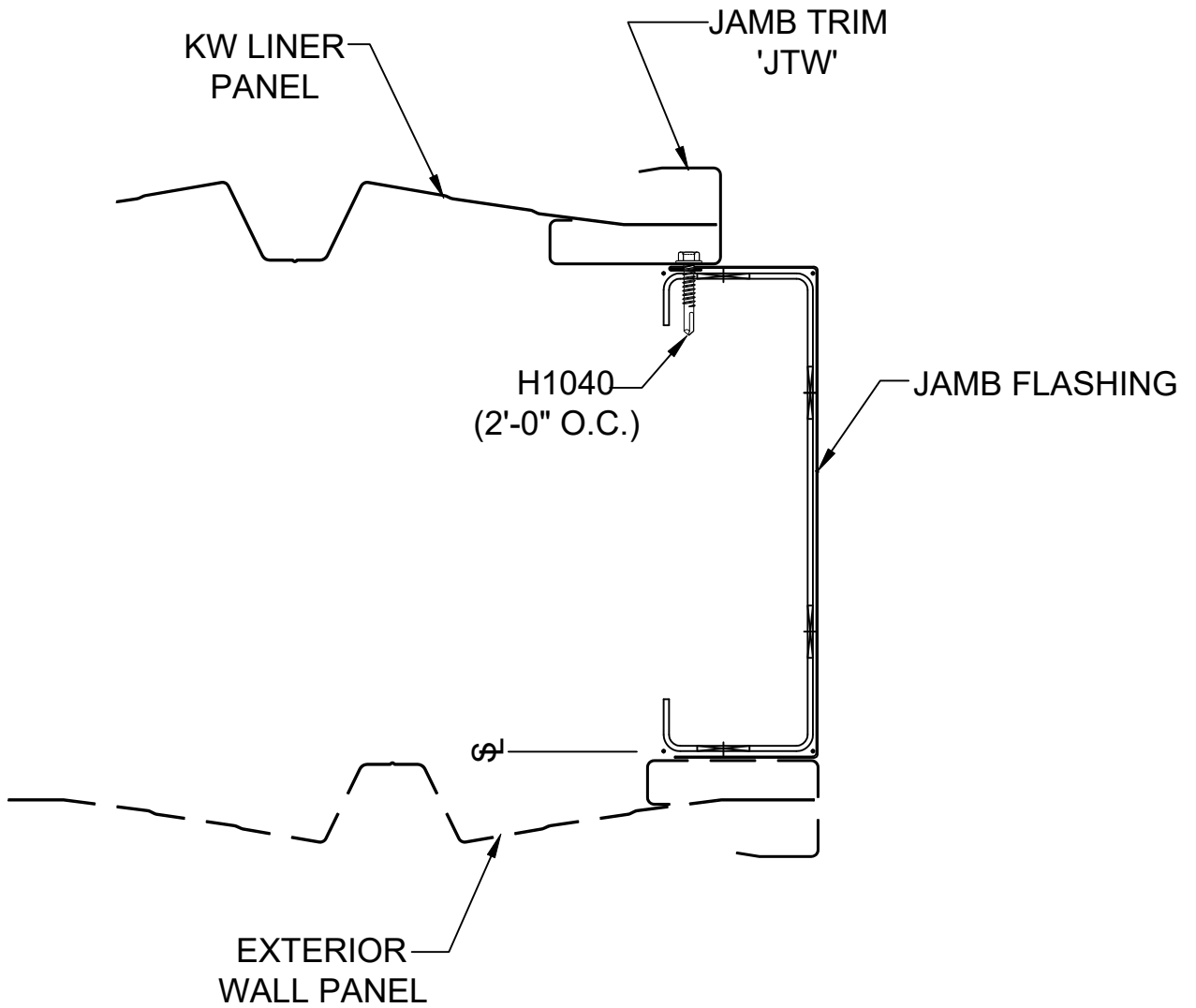

IG0151K

LINER AT JAMB WITH KIRBYWALL LINER PANEL



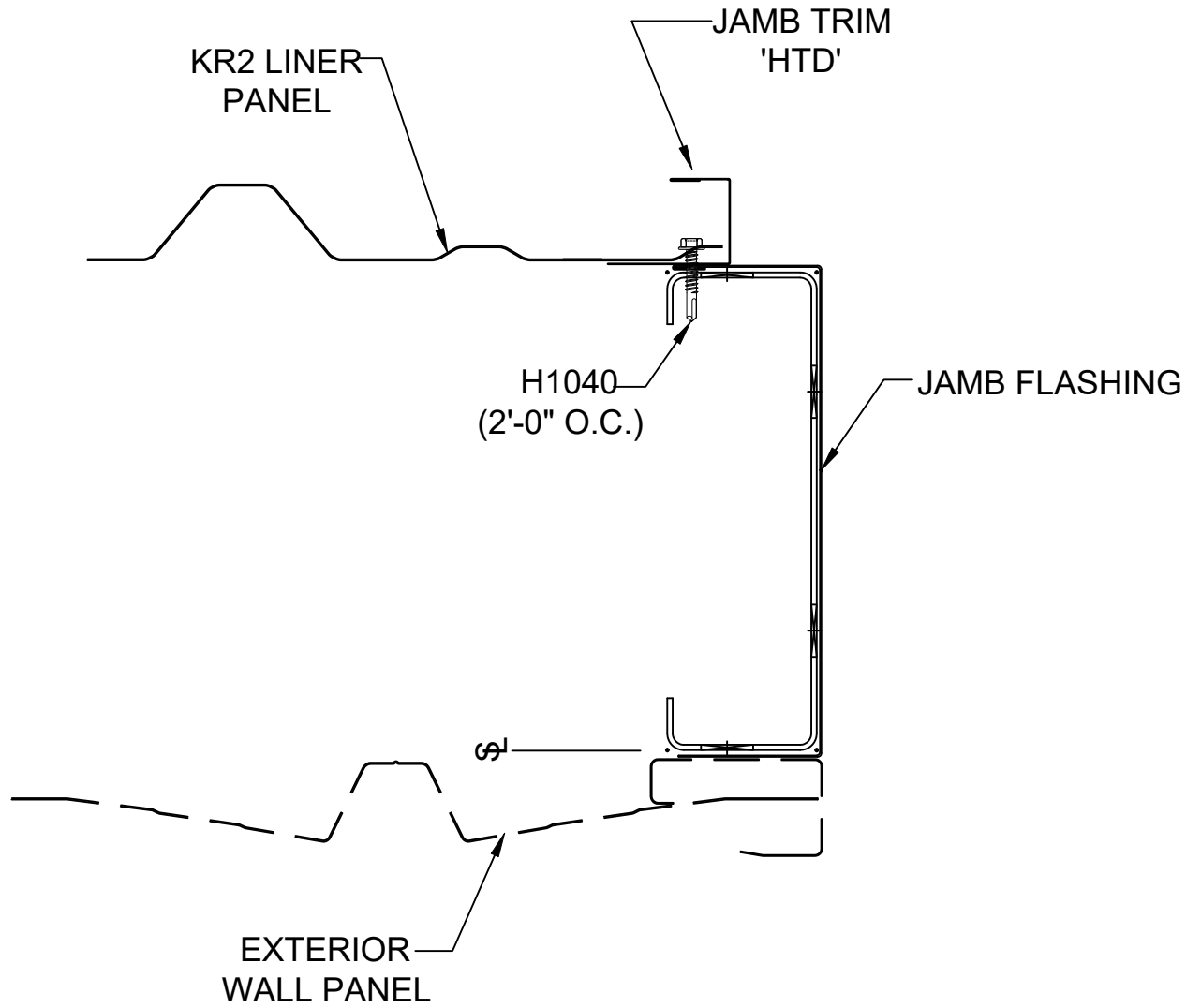

IG0251K

LINER AT JAMB WITH KR2 LINER PANEL

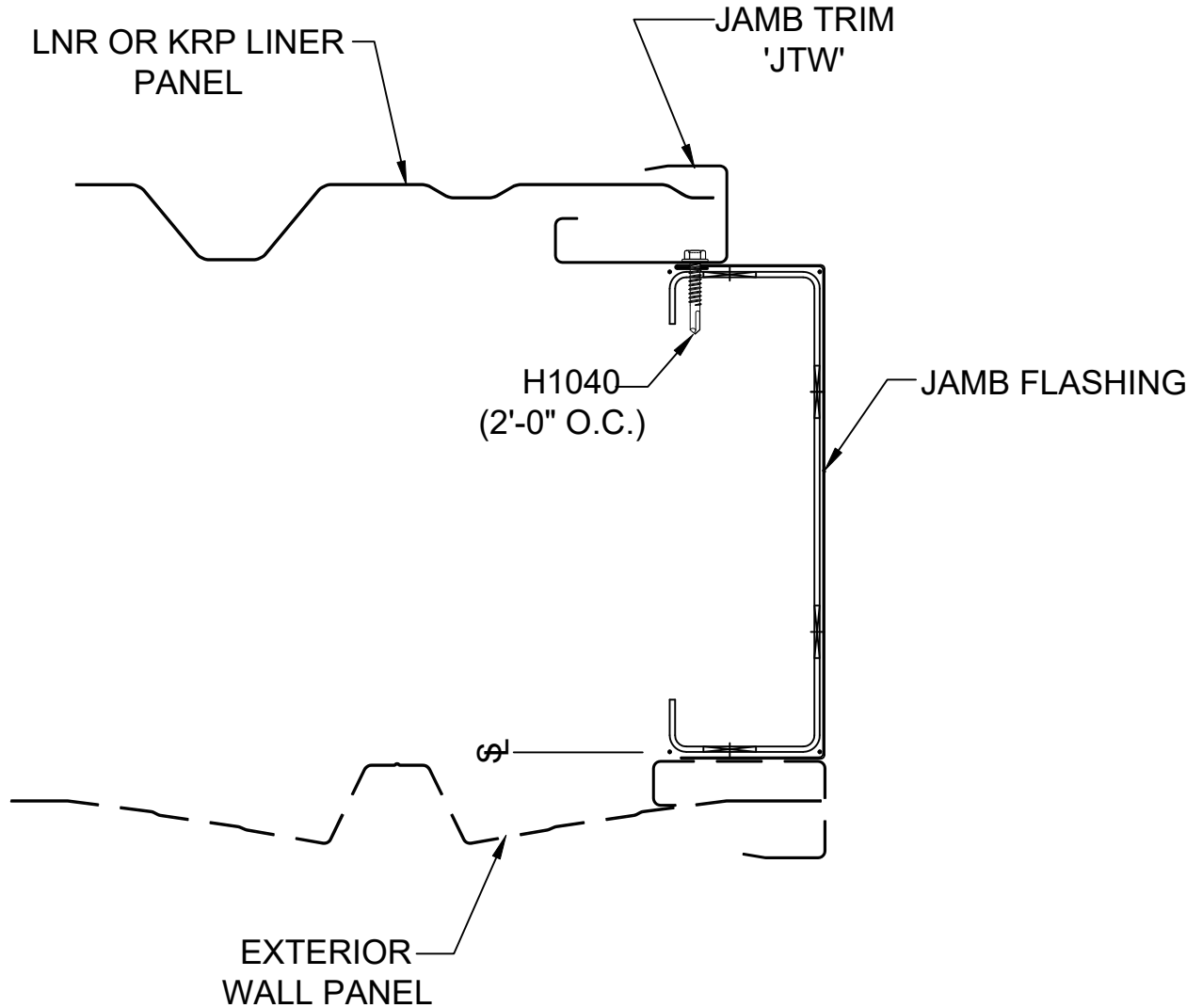

IG0351K

LINER AT JAMB WITH KRP LINER PANEL

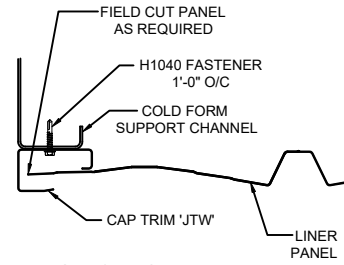
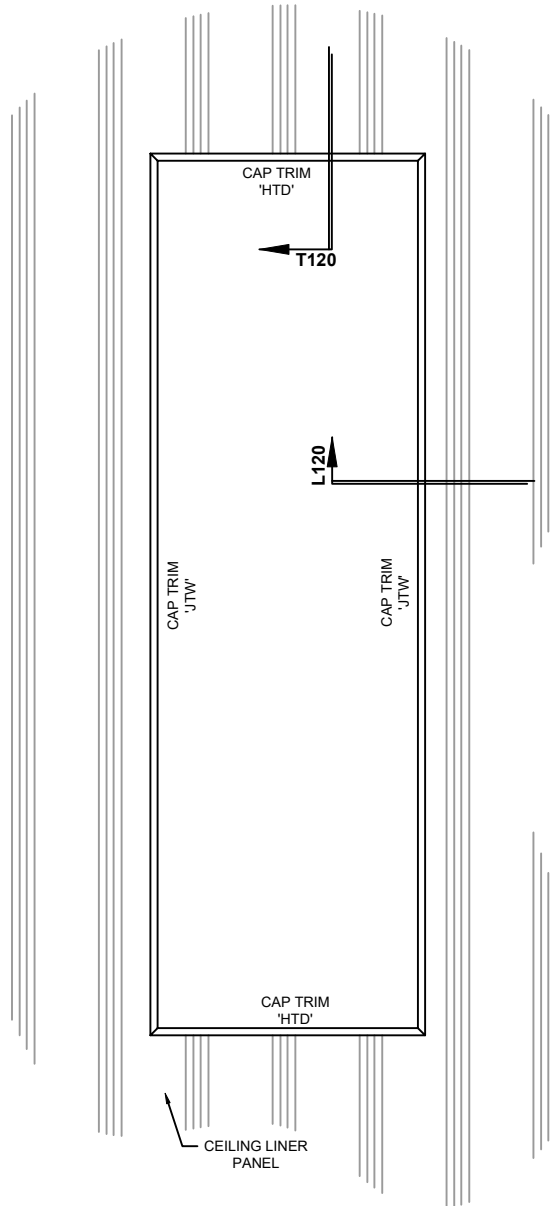
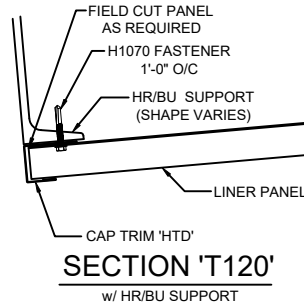
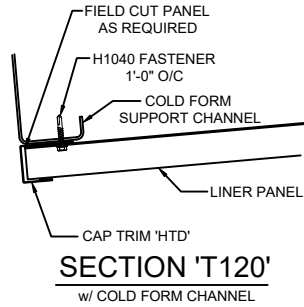

**SECTION 'L120'**  
w/ COLD FORM CHANNEL

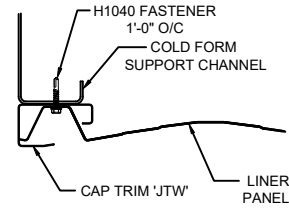

**SECTION 'L120'**  
w/ COLD FORM CHANNEL AND ALTERNATE PANEL FINISH

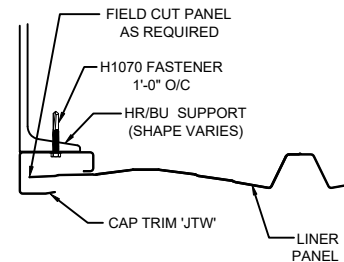

**SECTION 'L120'**  
w/ HR/BU SUPPORT

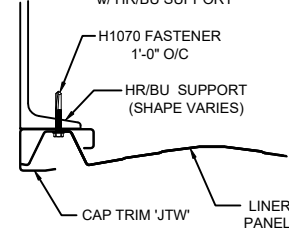

**SECTION 'L120'**  
w/ HR/BU SUPPORT AND ALTERNATE PANEL FINISH

IG0120K

CEILING LINER OPENING TRIM INSTALLATION FOR KW LINER PANEL



BETTER SOLUTIONS. BETTER BUILDINGS.

PREPARED BY: BKC

DATE: 4-23-20

**IG0120**

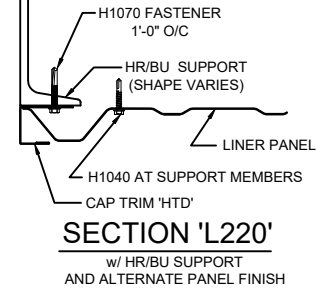
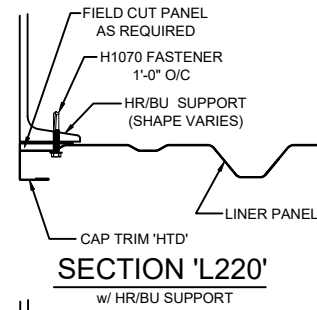
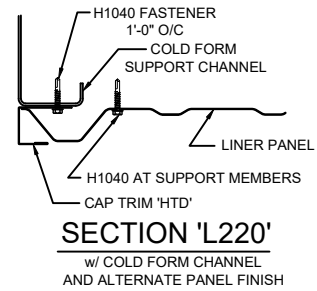
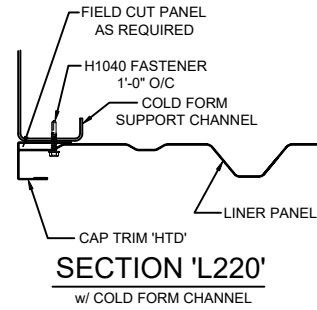
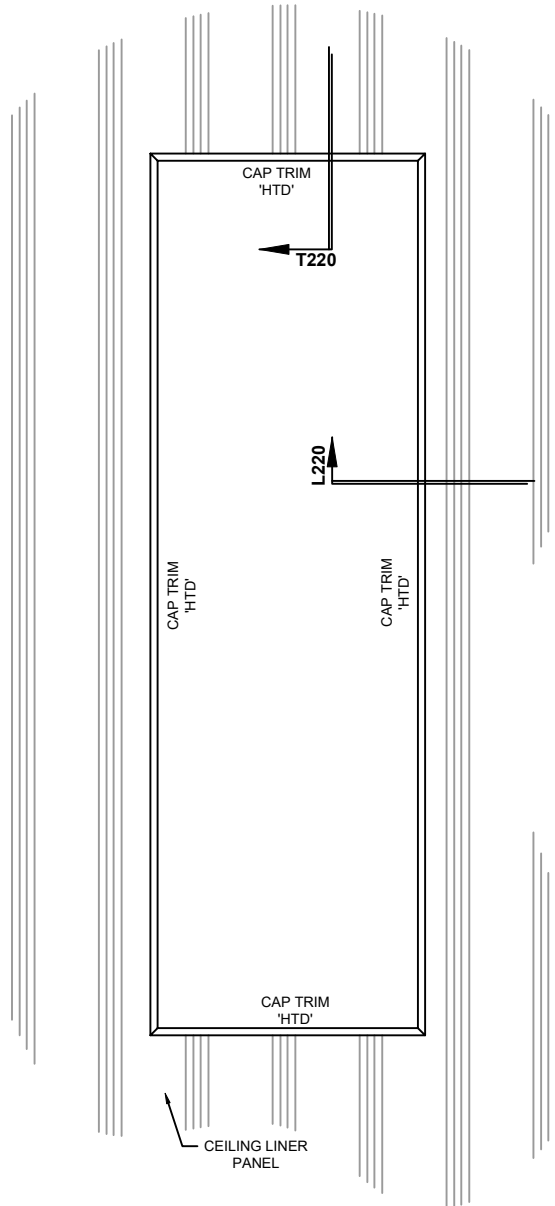
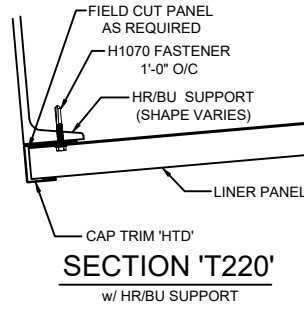
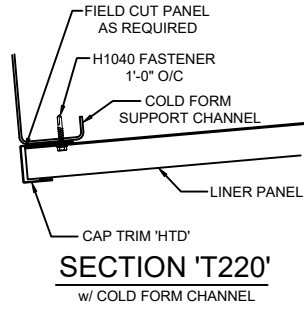

IG0220K

CEILING LINER OPENING TRIM INSTALLATION FOR KR2 LINER PANEL

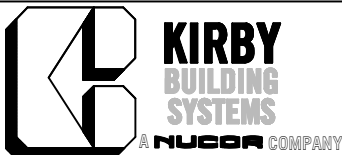

BETTER SOLUTIONS. BETTER BUILDINGS.

PREPARED BY: BKC

DATE: 4-23-20

IG0220

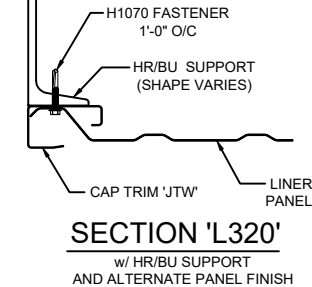
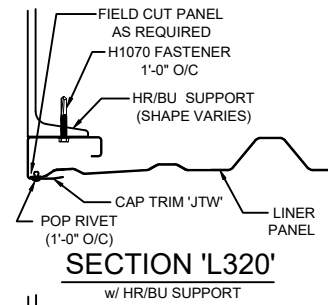
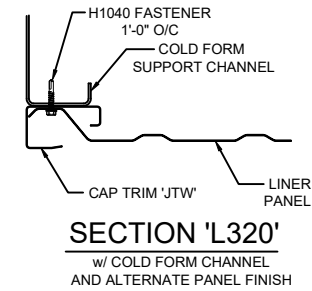
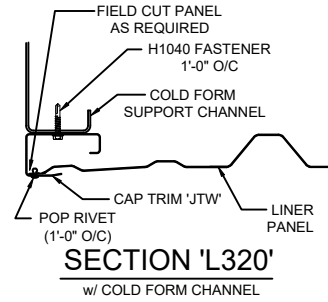
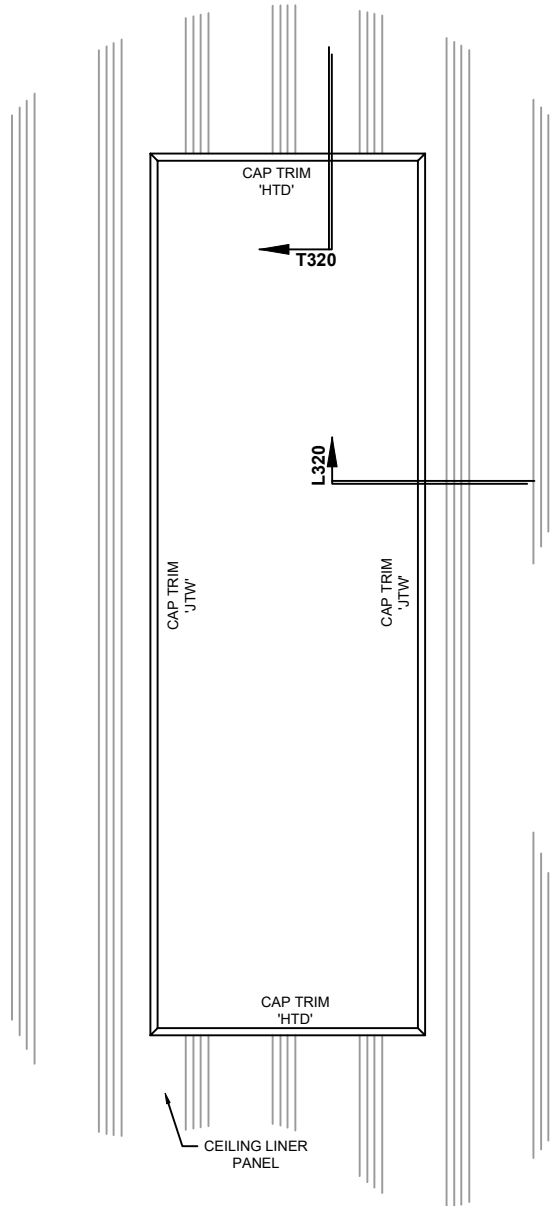
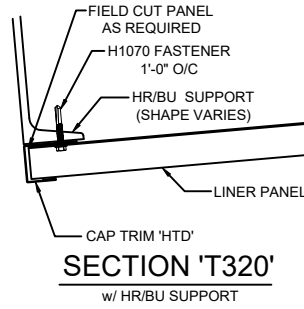
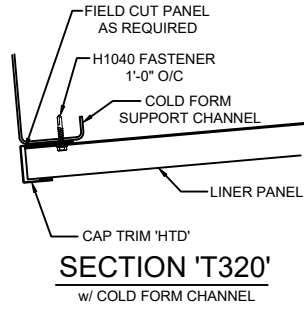

IG0320K

CEILING LINER OPENING TRIM INSTALLATION FOR KRP LINER PANEL



BETTER SOLUTIONS. BETTER BUILDINGS.

PREPARED BY: BKC

DATE: 4-23-20

**IG0320**