

AB0310 - EW Col. Connection at Peak
AB0509 - "C" Corner Col. to "C" Rafter
AB0511 - "C" Corner Col. to "I" Rafter
AB0520 - "I" Corner Col. to "I" Rafter
AB0544 - "C" EW Col. to "C" Rafter
AB0546 - "C" EW Col. to "I" Rafter
AB0580 - "I" EW Col. to "I" Rafter

AB0310 - ENDWALL COLUMN @ PEAK CONNECTION

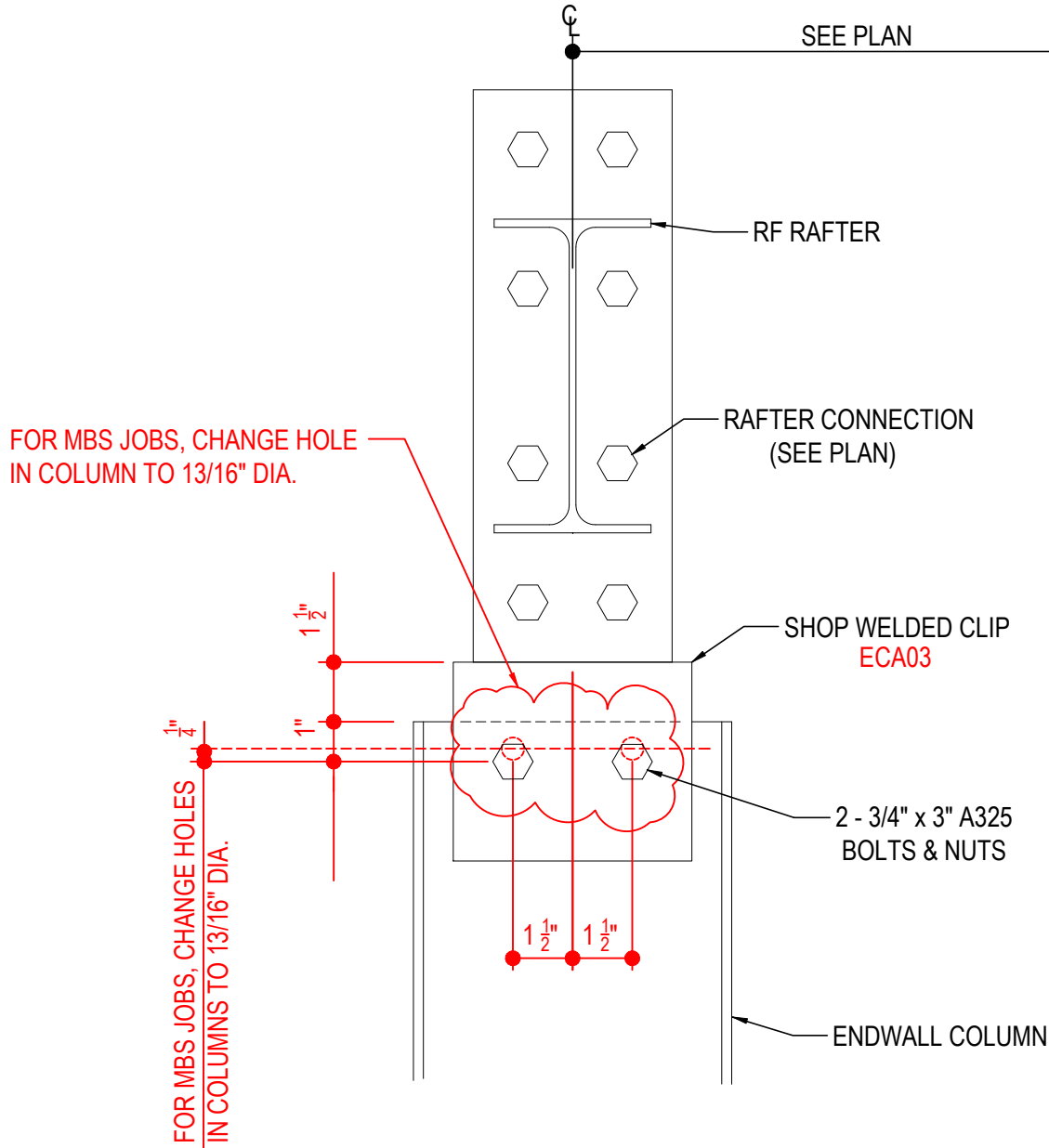

E'WALL COLUMN @ PEAK CONNECTION

ENDWALL COLUMN TO RAFTER
REFERENCE A00010 FOR WASHER REQUIREMENTS

AB0310

Detailer Notes:

- 1) N/A

AB0509 - CEE CORNER COLUMN TO CEE RAFTER CONNECTION

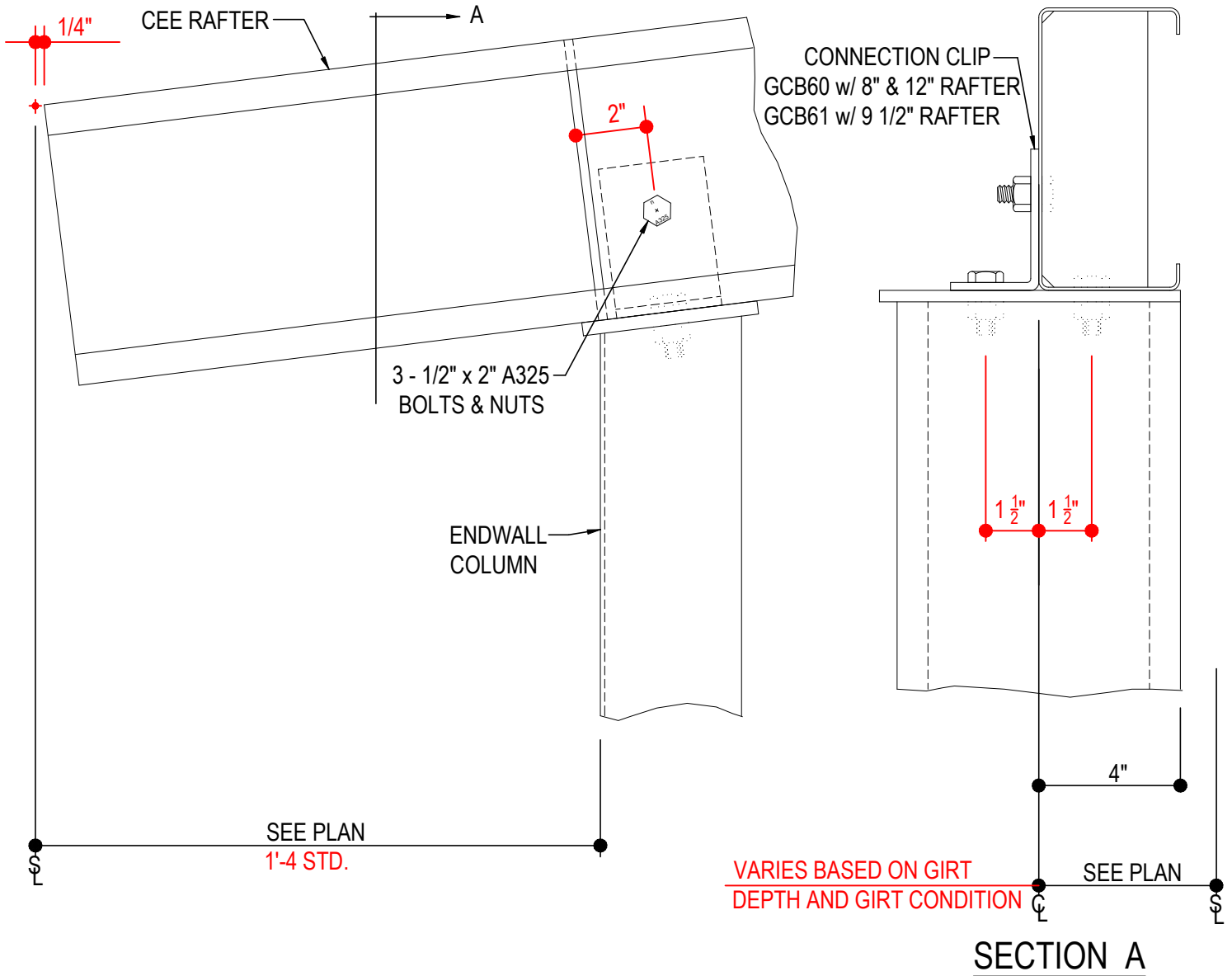

CEE CORNER COLUMN TO RAFTER CONNECTION

CEE CORNER COLUMN COLUMN TO CEE RAFTER

AB0509

Detailer Notes:

- 1) N/A

AB0511 - CEE CORNER COLUMN TO I SHAPED RAFTER CONNECTION

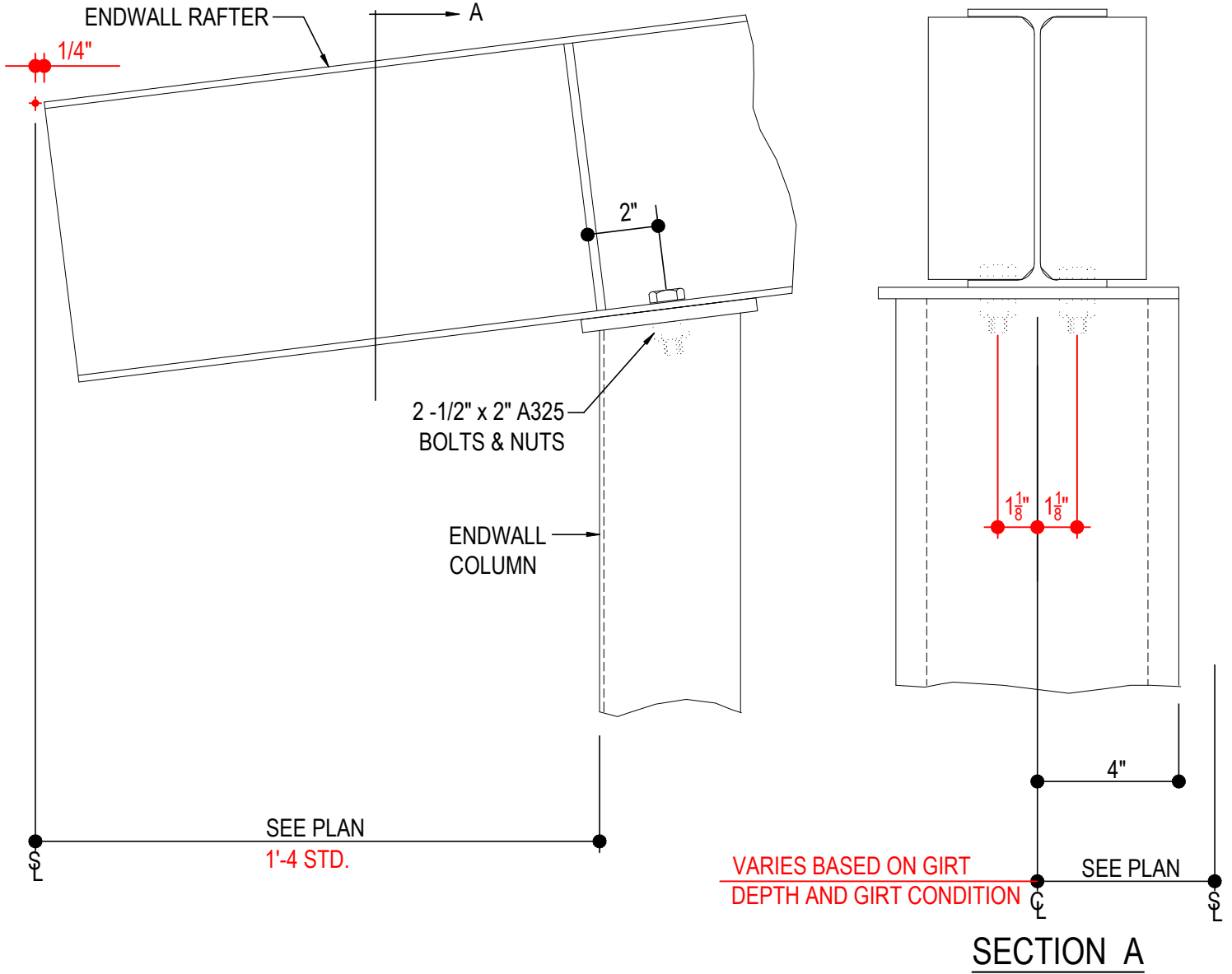

CEE CORNER COLUMN TO RAFTER CONNECTION

CEE CORNER COLUMN COLUMN TO I SHAPED RAFTER

AB0511

Detailer Notes:

- 1) N/A

AB0520 - I SHAPED CORNER COLUMN TO I SHAPED RAFTER CONNECTION

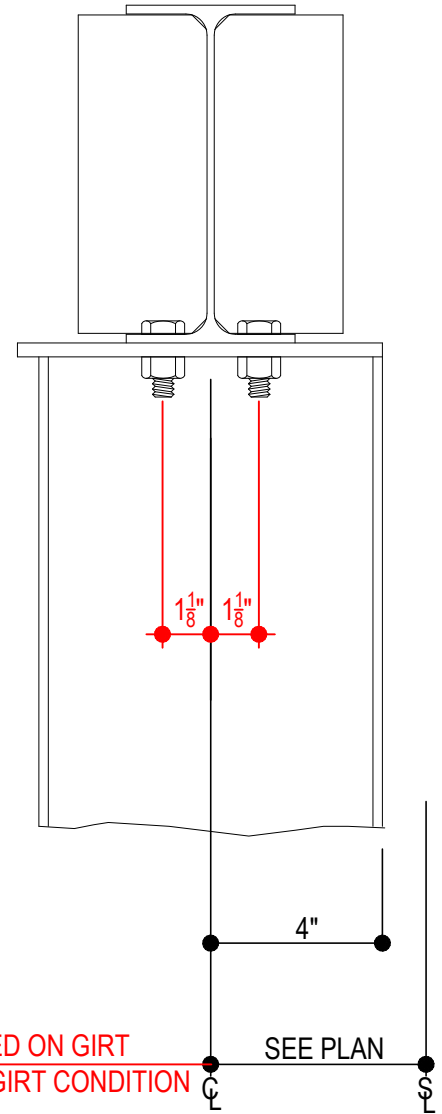
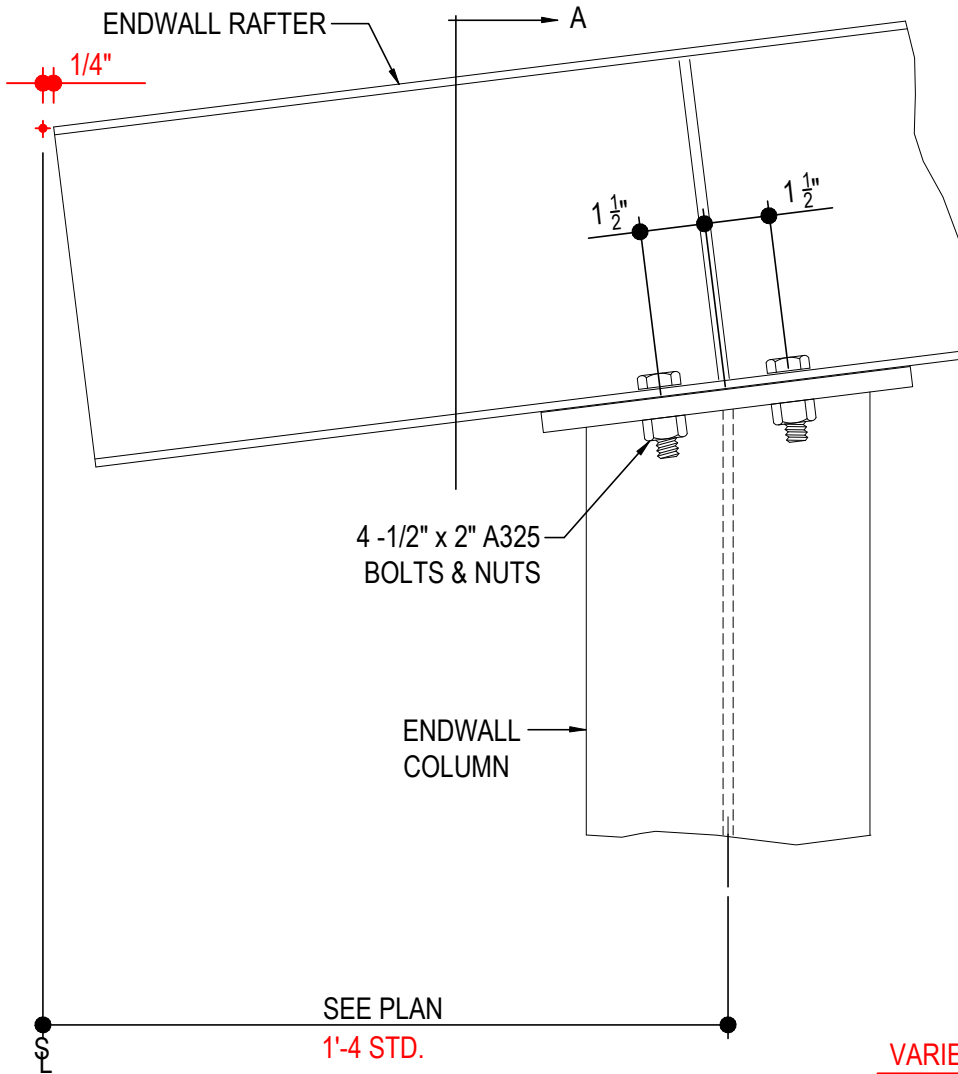

SECTION A

I CORNER COLUMN TO RAFTER CONNECTION

I SHAPED CORNER COLUMN TO I SHAPED RAFTER

AB0520

Detailer Notes:

- 1) N/A

AB0544 - CEE ENDWALL COLUMN TO CEE RAFTER CONNECTION

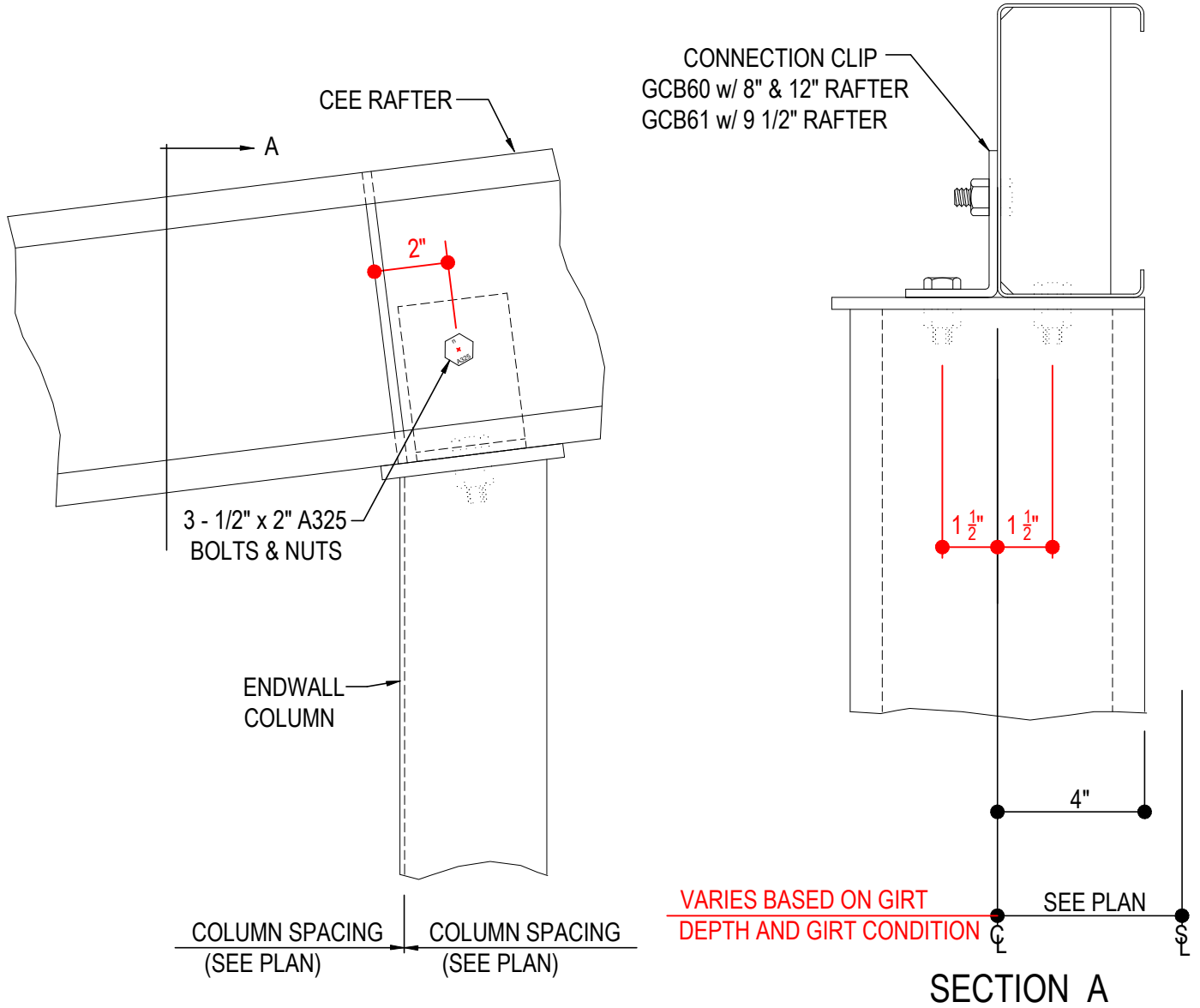

CEE ENDWALL COL. TO RAFTER CONNECTION

CEE ENDWALL COLUMN TO CEE RAFTER

AB0544

Detailer Notes:

- 1) N/A

AB0546 - CEE ENDWALL COLUMN TO I SHAPED RAFTER CONNECTION

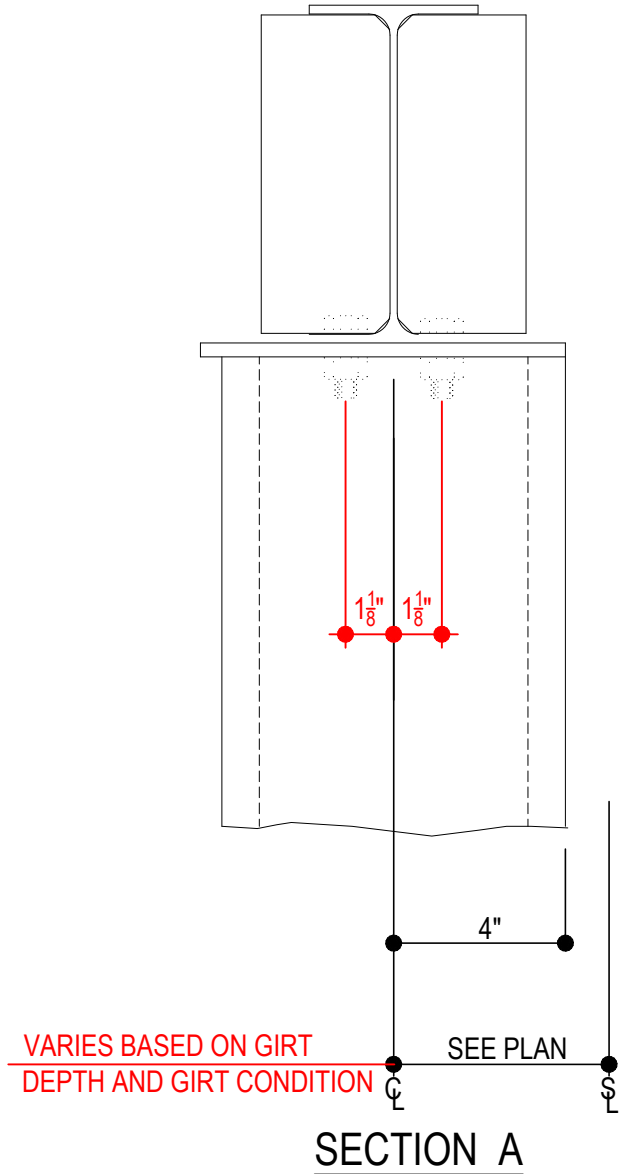
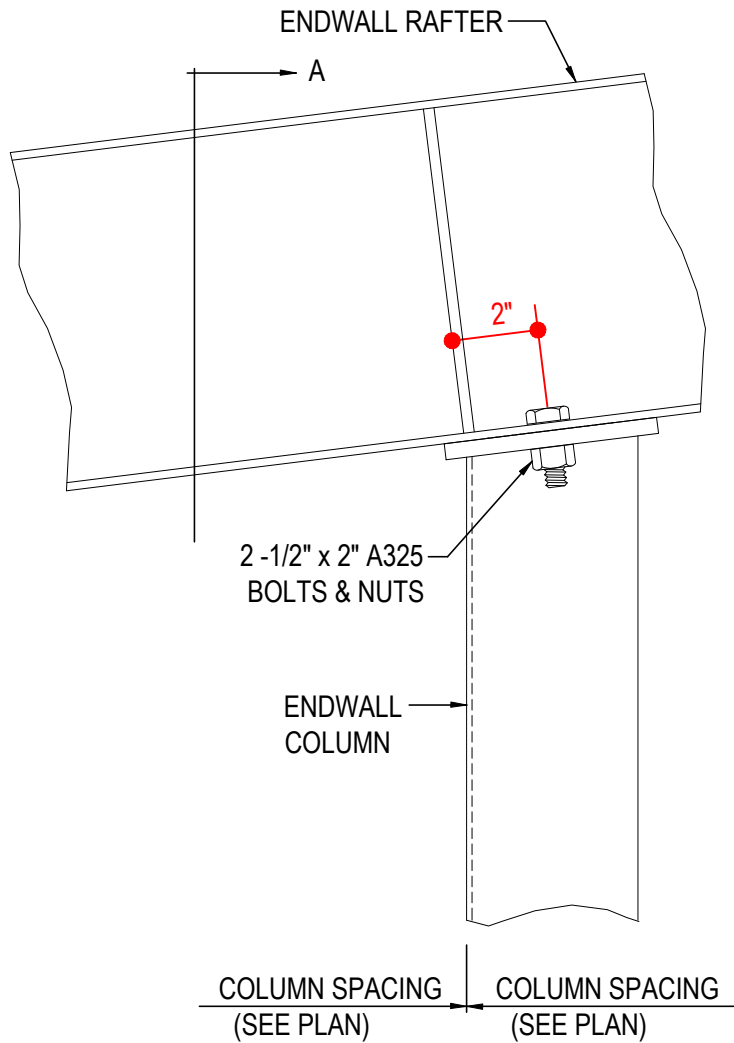

CEE ENDWALL COL. TO RAFTER CONNECTION

CEE ENDWALL COLUMN COLUMN TO I SHAPED RAFTER

AB0546

Detailer Notes:

- 1) N/A

AB0580 - I SHAPED ENDWALL COLUMN TO I SHAPED RAFTER CONNECTION

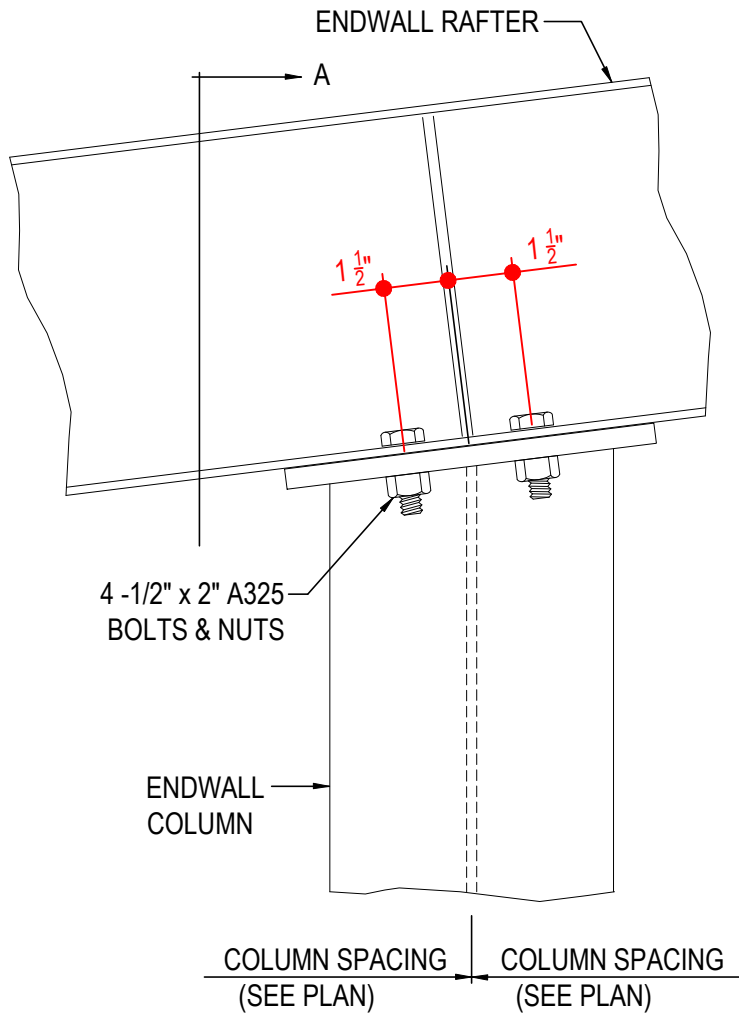

VARIES BASED ON GIRT DEPTH AND GIRT CONDITION

SEE PLAN

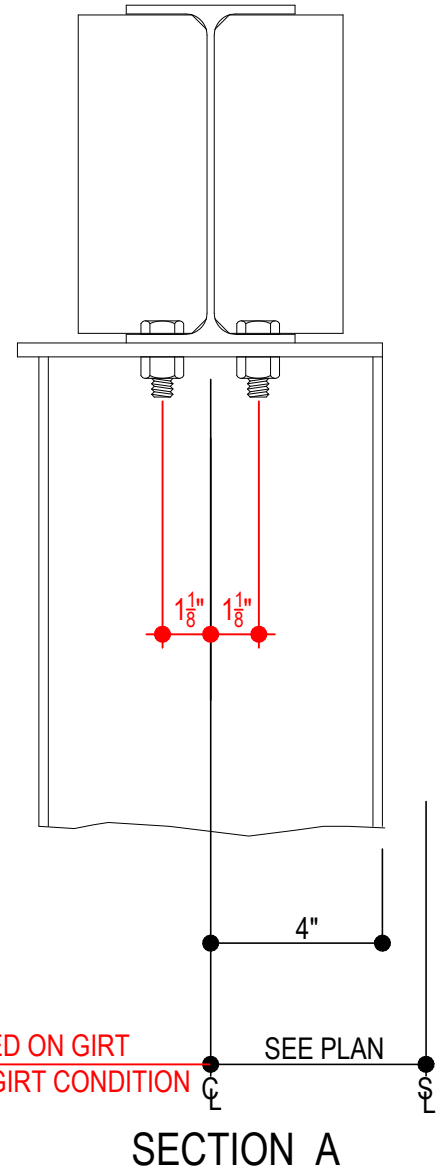

I ENDWALL COLUMN TO RAFTER CONNECTION

I SHAPED ENDWALL COLUMN TO I SHAPED RAFTER

AB0580

Detailer Notes:

- 1) N/A